



TET ESTEL AS
ESTONIA

February
2017

Series
TF262-125

Fast Stud Mounted Thyristor Type TF262-125

Low on-state and switching losses
Low reverse recovery charge
Center amplifying gate

Maximum mean on-state current						I_{TAV}	125 A			
Maximum repetitive peak off-state and reverse voltage						U_{DRM}	600 ÷ 1400 V			
Turn-off time						U_{RRM}				
						t_q	20; 25; 32 μs			
U_{DRM}, U_{RRM}, V	600	700	800	900	1000	1100	1200	1300	1400	
Voltage code	6	7	8	9	10	11	12	13	14	
$T_{vj}, ^\circ C$	- 60 ÷ 125									

MAXIMUM ALLOWABLE RATINGS

Symbols and parameters		Units	TF262-125	Conditions
I_{TAV}	Mean on-state current	A	125	$T_c=88^\circ C$, 180° half-sine wave, 50 Hz
I_{TRMS}	RMS on-state current	A	196	$T_c=88^\circ C$
I_{TSM}	Surge on-state current	kA	3,5 3,7	$T_{vj}=125^\circ C$ $T_{vj}=25^\circ C$ tp=10 ms
I^2t	Limiting load integral	kA^2s	61,2 68,4	$T_{vj}=125^\circ C$ $T_{vj}=25^\circ C$ UR=0
U_{DRM}, U_{RRM}	Repetitive peak off-state and reverse voltage	V	600÷1400	$T_j \min \leq T_{vj} \leq T_{jm}$ 180° half-sine wave, 50 Hz Gate open
U_{DSM}, U_{RSM}	Non-repetitive peak off-state and reverse voltage	V	660÷1500	$T_j \min \leq T_{vj} \leq T_{jm}$ 180° half-sine wave tp=10 ms, Single pulse Gate open
$(di_T/dt)_{crit}$	Critical rate of rise of on-state current : non - repetitive repetitive	A/ μ s	800 400	$T_{vj}=125^\circ C$; $U_D=0,67 U_{DRM}$, Gate pulse : 10V, 5 Ω , 1 μ s rise time, 10 μ s
U_{RGM}	Peak reverse gate voltage	V	5	$T_j \min \leq T_{vj} \leq T_{jm}$
T_{stg}	Storage temperature	$^\circ C$	-60÷80	
T_{vj}	Junction temperature	$^\circ C$	-60÷125	

CHARACTERISTICS

U_{TM}	Peak on-state voltage	V	2,2	$T_{vj}=25^\circ C$, $I_{TM}=3,14 I_{TAV}$
$U_{T(To)}$	Threshold voltage	V	1,45	$T_{vj}=125^\circ C$
R_T	On-state slope resistance	m Ω	2,5	1,57 $I_{TAV} < I_T < 4,71 I_{TAV}$
I_{DRM} I_{RRM}	Repetitive peak off-state and reverse current	mA	25 25	$T_{vj}=125^\circ C$, $U_D = U_{DRM}$ $U_R = U_{RRM}$

CHARACTERISTICS

Symbols and parameters		Units	TF262-125	Conditions
I_L	Latching current	A	0,7	$T_{vj}=25^{\circ}\text{C}, U_D=12\text{V}$ Gate pulse : 10V, 5 Ω , 1 μs rise time, 10 μs
I_H	Holding current	A	0,3	$T_{vj}=25^{\circ}\text{C}, U_D=12\text{V}$, Gate open
U_{GT}	Gate trigger direct voltage	V	2,5 5,0	$T_{vj}=25^{\circ}\text{C}$, $T_{vj}=-60^{\circ}\text{C}$
I_{GT}	Gate trigger direct current	A	0,25 0,6	$T_{vj}=25^{\circ}\text{C}$, $T_{vj}=-60^{\circ}\text{C}$
U_{GD}	Gate non-trigger direct voltage	V	0,25	$T_{vj}=125^{\circ}\text{C}$, $U_D = 0,67 U_{DRM}$
I_{GD}	Gate non-trigger direct current	mA	10	Direct gate current
t_{gd}	Delay time	μs	1,4	$T_{vj}=25^{\circ}\text{C}, U_D=500\text{V}$ $I_{TM} = 125\text{ A}$
t_{gt}	Turn-on time	μs	3,2	Gate pulse : 10V, 5 Ω , 1 μs rise time, 10 μs
t_q	Turn-off time	μs	20÷32 25÷40	$T_{vj}=125^{\circ}\text{C}$, $I_{TM}=125\text{ A}$ $di_R/dt = 10\text{ A}/\mu\text{s}$, $U_R=100\text{V}$ $U_D = 0,67 U_{DRM}$ $du_D/dt=50\text{ V}/\mu\text{s}$ $du_D/dt=200\text{ V}/\mu\text{s}$
Q_{rr}	Recovered charge	μC	165	$T_{vj}=125^{\circ}\text{C}$, $I_{TM}=125\text{ A}$
t_{rr}	Reverse recovery time	μs	3,3	
I_{rrM}	Peak reverse recovery current	A	100	$di_R/dt = 50\text{ A}/\mu\text{s}$, $U_R=100\text{V}$
$(du_D/dt)_{crit}$	Critical rate of rise of off-state voltage	V/ μs	500 1000	$T_{vj}=125^{\circ}\text{C}$, $U_D = 0,67 U_{DRM}$ Gate open
R_{thjc}	Thermal resistance junction to case	$^{\circ}\text{C}/\text{W}$	0,12	Direct current

ORDERING

	TF	262	125	14	6	6	2	
	1	2	3	4	5	6	7	

1. Fast thyristor.
2. Design version.
3. Mean on-state current, A.
4. Voltage code (14=1400 V).
5. Critical rate of rise of off-state voltage ($6 \geq 500\text{ V}/\mu\text{s}$, $7 \geq 1000\text{ V}/\mu\text{s}$).
6. Group of turn-off time ($du_D/dt=50\text{ V}/\mu\text{s}$, $4 \leq 32\ \mu\text{s}$, $5 \leq 25\ \mu\text{s}$, $6 \leq 20\ \mu\text{s}$).
7. Group of turn-on time ($2 \leq 3,2\ \mu\text{s}$).

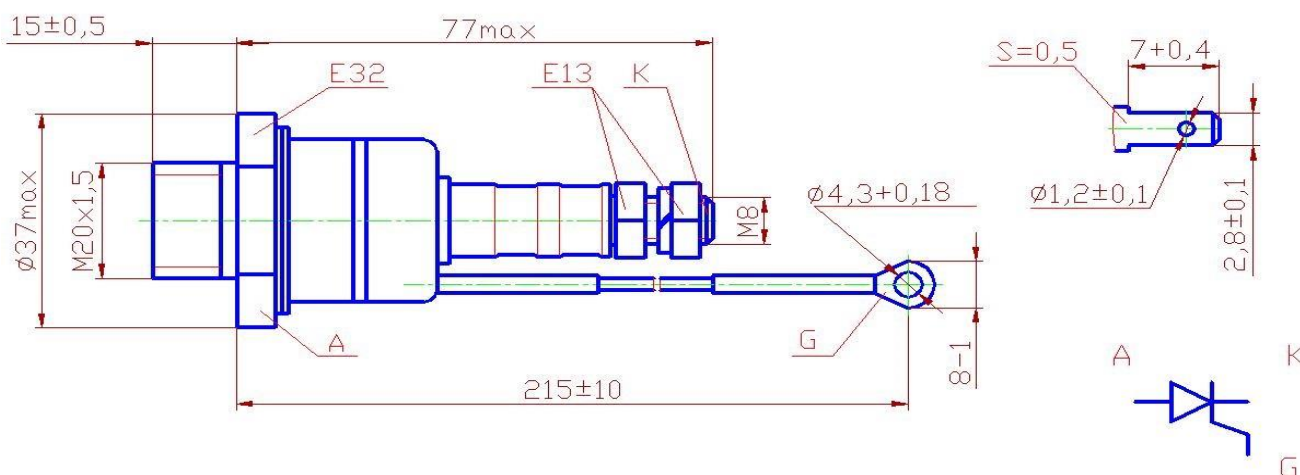

Tightening torque : 24 ÷ 36 Nm
Weight : 220 grams